

Specifications

Size (L x W x H):	4.55" x 2.55" x 1.65" (115mm x 65mm x 41mm)
TR-INR-S Weight:	8.8oz (250g)
TR-INR-S Enclosure Material:	Die-Cast Aluminum Alloy
TR-INR-C Weight:	5.5oz (155g)
TR-INR-C Enclosure Material:	Polycarbonate
Operating Voltage Range:	5 – 18 VDC
Current Consumption:	60mA @ 12VDC
Measurement Range:	0 – 5g, X and Y Axes
Operating Temperature Range:	-22°F to +160°F (-30C to +70C)
Operating Humidity Range:	0 – 95% RH, non-condensing

Because of continuous product improvements, specifications are subject to change without notice. Please contact Seon Design™ for the latest product specifications.

Service and Warranty

If your product is to be returned to Seon Design™ for service, please call toll free 877-630-7366, or 604-941-0880 and ask for a Return Authorization (RA) number. An RA number allows the Service Technicians to better track your product when it comes in for service. Please show the RA number on the outside of the package. ANY PRODUCT SENT TO SEON DESIGN™ WITHOUT AN RA NUMBER MAY BE REFUSED.

Please refer to the Warranty form provided with your product to review the terms of warranty service, contact and shipping information, as well as other important information regarding the service and operation of your product.

© 2006 Seon Design™ Inc.
All rights reserved.
Document Part Number: 700-0041 R001

1 Features

The Seon™ TR-INR is a Multi-Axis Accelerometer that measures acceleration in two axes – X and Y, or ‘Side-to-Side’ (X) and ‘Front-to-Back’ (Y). The module also computes a ‘vector’ (V) output, which measures acceleration at angles between X and Y.

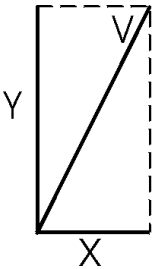

This is similar to a right-angle triangle, where X and Y are the sides of the triangle and V is the length of the hypotenuse.

Other features of the TR-INR include:

- The model TR-INR-S comes in a heavy duty, IP66 sealed metal enclosure.
- The model TR-INR-C comes in a heavy duty polycarbonate enclosure with a clear window cover
- A multi-character display to show the acceleration in each axis or vector.
- An audible indicator on the Vector output in the TR-INR-C used to alert the driver when preset limits for cornering and braking have been exceeded.
- Programmable trip points for the X and Y directions, as well as the V direction, from 0.1g up to 5g in 0.1g increments.
- Three independent signal/alarm outputs: X, Y, and V.
- Peak levels recorded on each axis.
- An optional CAN vehicle network interface.

SEON

TR-INR Inertia Sensor

Installation and User Guide

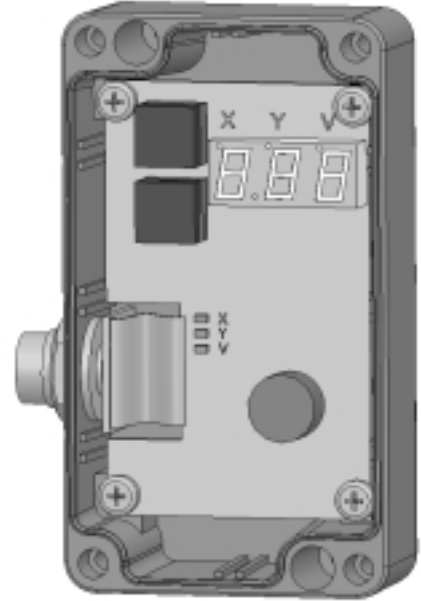

2 Installation

- 1 Remove the enclosure cover using a #2 Philips screwdriver to remove the four screws in the corners of the enclosure.
- 2 In the corners of the enclosure there are two through-holes for mounting the enclosure. Use the enclosure as a template to mark the mounting hole locations. Note that the TR-INR must be mounted on a flat surface that should be as close to horizontal as possible. Also, the enclosure must be mounted with Y direction (the long side of the enclosure) in the direction that the vehicle travels (i.e. front-to-back) for monitoring acceleration and braking. The X direction (the short side of the enclosure) monitors the side-to-side direction for cornering.

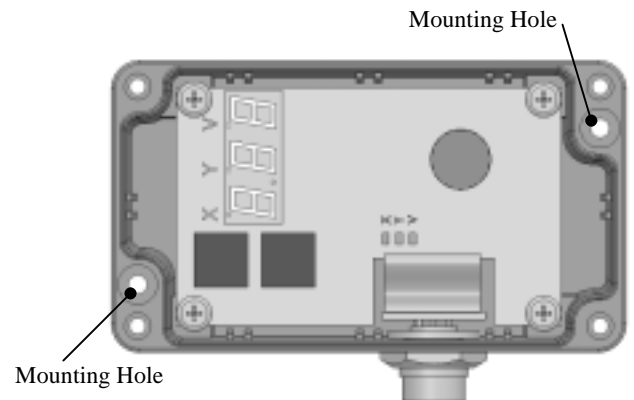

Figure 1 – Mounting Holes

- 3 Drill pilot holes for mounting the enclosure and use the supplied #8 x 3/4 sheet metal screws to secure the enclosure to the mounting surface.

3 Cable Connections

- 1 The cable connection on the TR-INR is a sealed, twist-on style. Plug in the mating connector on the TR-INR cable and twist the collar to lock the cable connector.
- 2 Depending on the installation, the other end of the TR-INR cable may be the same sealed connector (TR-HAxx) for use with an adapter harness, or the cable may have a power connector and three flying wires. As the connections to the DVR are the same, an adapter harness is shown below:

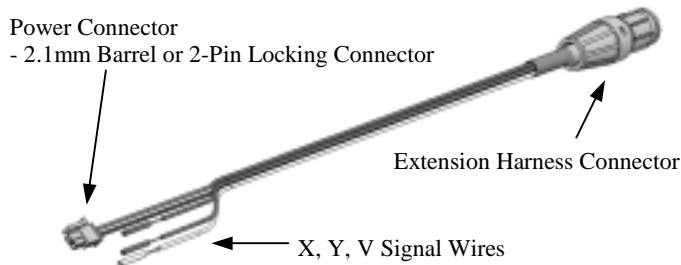

Figure 2 – Adapter Harness

- 3 The power connector on the end of the harness plugs into the Auxiliary Power Jack on the back of the Trooper DVR, or into the Auxiliary Power Jack on the Smart-Link Module used with the Explorer DVR's.
- 4 The three remaining wires are the X (Brown wire), Y (Green wire), and V (White wire) signal outputs. They can be wired to the Signal Inputs or the Alarm Input(s) on the DVR. They can also be connected together into one signal or alarm input, although the DVR cannot determine which input caused the signal or alarm. Connections are made using the supplied splice connectors.

4 Programming and Use

- 1 When first powered up, the TR-INR is in the Acceleration display mode and either of the two buttons can be used to cycle through the real time and peak recorded acceleration values from the sensor. The three small lamps at the top of the display are lit solid when viewing the live X, Y, and V acceleration. The lamps flash when viewing the corresponding peak recorded acceleration values.

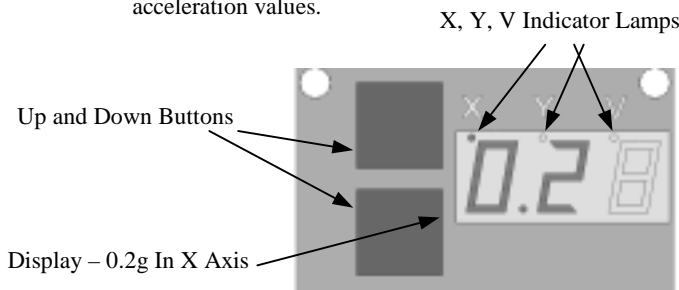

Figure 3 – TR-INR Display

- 2 To put the sensor into the program mode, hold both buttons down for about 2 seconds and the display will show a two-digit value, followed by a 'P' to signify program mode. The three lamps at the top of the display signify X, Y or V thresholds.

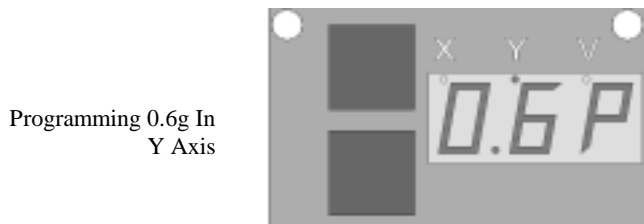

Figure 4 – Programming Mode

- 3 To change the value of the threshold, press and release both buttons. The top decimal will start to flash indicating that the threshold value can be changed up or down using the buttons. When the desired threshold is reached, press both buttons again to store the value.
- 4 The up down button may now be used to cycle through the various program options, as listed below.
 - \dot{x} .xP X Axis Threshold
 - \dot{y} .yP Y Axis Threshold
 - \dot{v} .vP Vector Threshold
 - clr Clear Peak values from memory
 - CAL Calibrate the sensor
 - E P Exit Programming mode and return to live display.
- 5 The 'clr' function is executed by pressing and releasing both buttons when 'clr' is displayed. When successful, the small lamps above the characters will light.
- 6 The 'CAL' function allows the unit to be calibrated for zero G display. This should only be done when the unit is in a horizontal position (as close to level as possible). The Calibration should be done after the unit is mounted in the vehicle. Press and release both buttons simultaneously to calibrate the unit. The small lamps above the characters will light when complete.
- 7 The TR-INR can be programmed to work as both a driver training aid and as an impact sensor, with separate signal and alarm outputs for each. For driver training, set the X and Y signal trip levels to the values comfortable for the vehicle passengers. Note that 1g acceleration is equal to the force of gravity. Setting the X signal trip level to 1g may be unreasonable as it implies that the vehicle is moving sideways (or cornering) at a very high level (similar to a racing car). For braking, 1g deceleration (negative acceleration) is quite high, similar to a high-performance sports car. Try experimenting by cornering and braking at different rates and review the peak levels recorded by the TR-INR.
- 8 For impacts, the sudden change in acceleration, while not sustained, can be quite high. Set the V signal trip level to a higher level than recorded by the cornering and braking experiment in step 7 above. Connect the V output wire from the harness to the alarm input on the DVR.

5 Technical Notes

- 1 The X, Y, and V outputs are 'open-collector' style outputs. In the TR-INR, this means that, when they are activated, the signal is connected to 0V, or ground. This also means that the signal outputs can be connected to other 'open-collector' style signals.
- 2 The TR-INR is sensitive to impacts on the enclosure. The device cannot determine if the vehicle has been impacted (or braked too hard) or if someone/something hit the enclosure. Make sure the enclosure is securely mounted to avoid possible signal contamination.
- 3 On some large vehicles, the suspension may allow for impacts at the rear of the vehicle to be suppressed at the front of the vehicle. If the TR-INR is mounted at one end of the vehicle, it may not detect an impact at the other end. Because of the 'open-collector' style signal outputs, two TR-INR devices can be used on the same vehicle – one at the front and one at the back. The X, Y, and V outputs can be tied to the same outputs from the other detector and then connected to the DVR. To power up two TR-INR sensors, please contact Seon™ for a special power harness.
- 4 For testing purposes, there are three small green lamps (labeled X, Y, and V) in the middle of the module that illuminate when the corresponding signal threshold has been exceeded.